



**WORLD
OBSTACLE**

FÉDÉRATION INTERNATIONALE DE SPORTS D'OBSTACLES

**OCR 100 M
COURSE
SPECIFICATION
MANUAL**

as of 1 August 2024

OCR 100m Course Specification Manual

This document defines the course requirements and specification for the international standard OCR 100 m. All dimensions must be verified by an independent auditor per the World Record Guide to Evidence if the course is used to establish national, continental, or world records. View a computer simulation fly through of the course [here](#).

1. OVERVIEW

The international standard OCR 100m is a one hundred meter (100 m) long “sprint” obstacle course race (OCR) with twelve (12) standard obstacles, validated by Fédération Internationale de Sports d'Obstacles (FISO) for international competitions and records. The course may be one or more lanes arranged with the finish lines in the same location (lanes that are parallel, radial, etc.) Courses may be linear or curved (minimum radius 63.66 m (90 degrees of a 400.00 m circumference circle)

2. COURSE LENGTH & SLOPE

The Length of the course is 100.00 meters from the start line to the finish line. The course must be flat and level to less than a 1% slope in any direction (10 mm per meter), e.g. no more than 1.0 m drop or rise of over the length of the course.

Minimum lane width is 1.2 m (4 ft), 1.5 m (5 ft) is recommended to provide clearance between athletes and obstacle support structures.

3. OBSTACLE STRUCTURES

Obstacle support structures, including platforms, walls, and hanging obstacle frames (money bars, wheels, rings, climbing holds, Tarzan swing) must not appreciably move or deform during competition. Structures should be capable of supporting athletes weighing 110 kg in motion at speeds of up to 5.5 meters per second (20 km/h).

Structures may be constructed from metal, wood, plastic, or a combination of materials that satisfy the above criteria. *If horizontal sections are constructed from two or more pieces, joints must be verified by an engineer or other qualified person to ensure they are structurally sound under expected conditions. Pinned joints are strongly discouraged, plated box truss OK. Nuts on bolted joints should be tightened with an impact drill and include lock washers.*

4. SAFETY PADDING

Safety padding (mats) shall be provided in all areas where athletes can contact a structure, platform, frame, step, or ground surface. Safety padding over hard ground surfaces under hanging obstacles should be 200 mm (8 inches) thick and 21 kg/m³. Climbing crash mats and gymnastics tumbling mats typically meet these criteria. Platform, step surfaces and low crawl padding should be 20 mm thick and 80 kg/m³ (standard grip martial arts mats or equivalent).

FISO OCR 100 m Standard Course Obstacle Layout

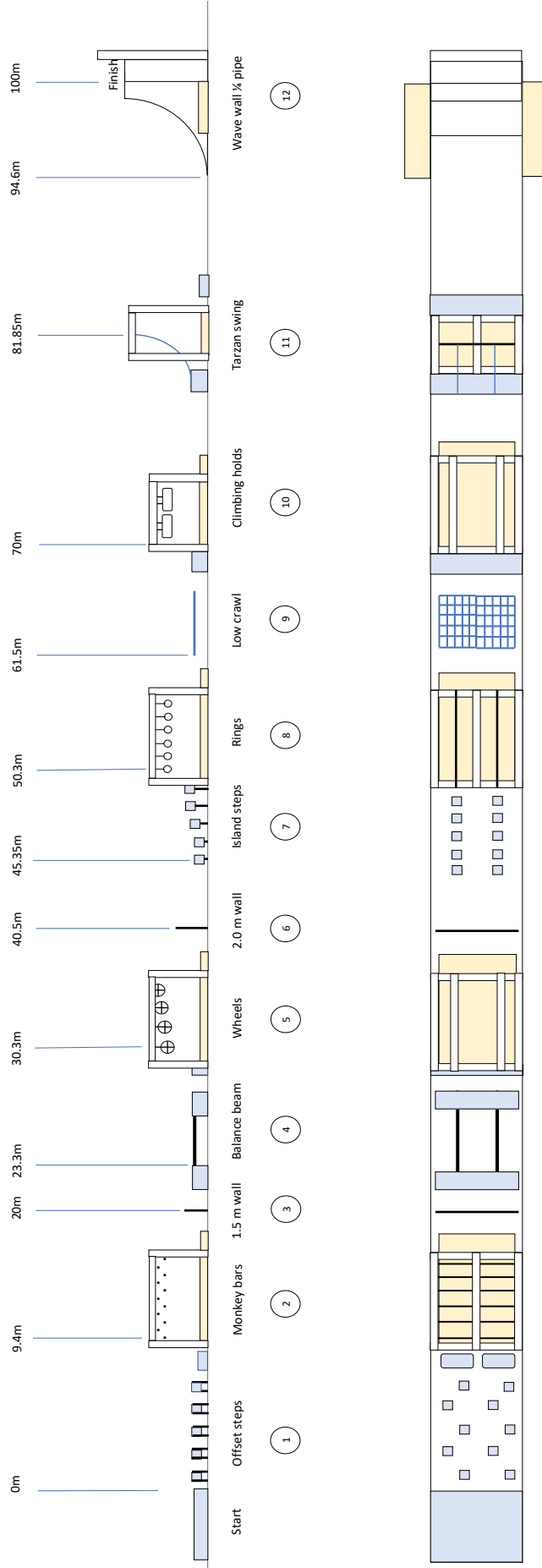

Version 2024.01.13
Not to Scale

5. OBSTACLES

Suspended obstacles (monkey bars, wheels, rings, climbing holds, rope swing) are hung from a wood or metal frame, ideally stage trussing to allow banners to be mounted effectively. Scaffolding or wood framing can be used but requires additional engineering and is not as visually appealing as trussed obstacle frames. The images shown include trussed and scaffold obstacles, courtesy of Obstacle Formula (Epik Engineering) and Hannibal's Crossing.

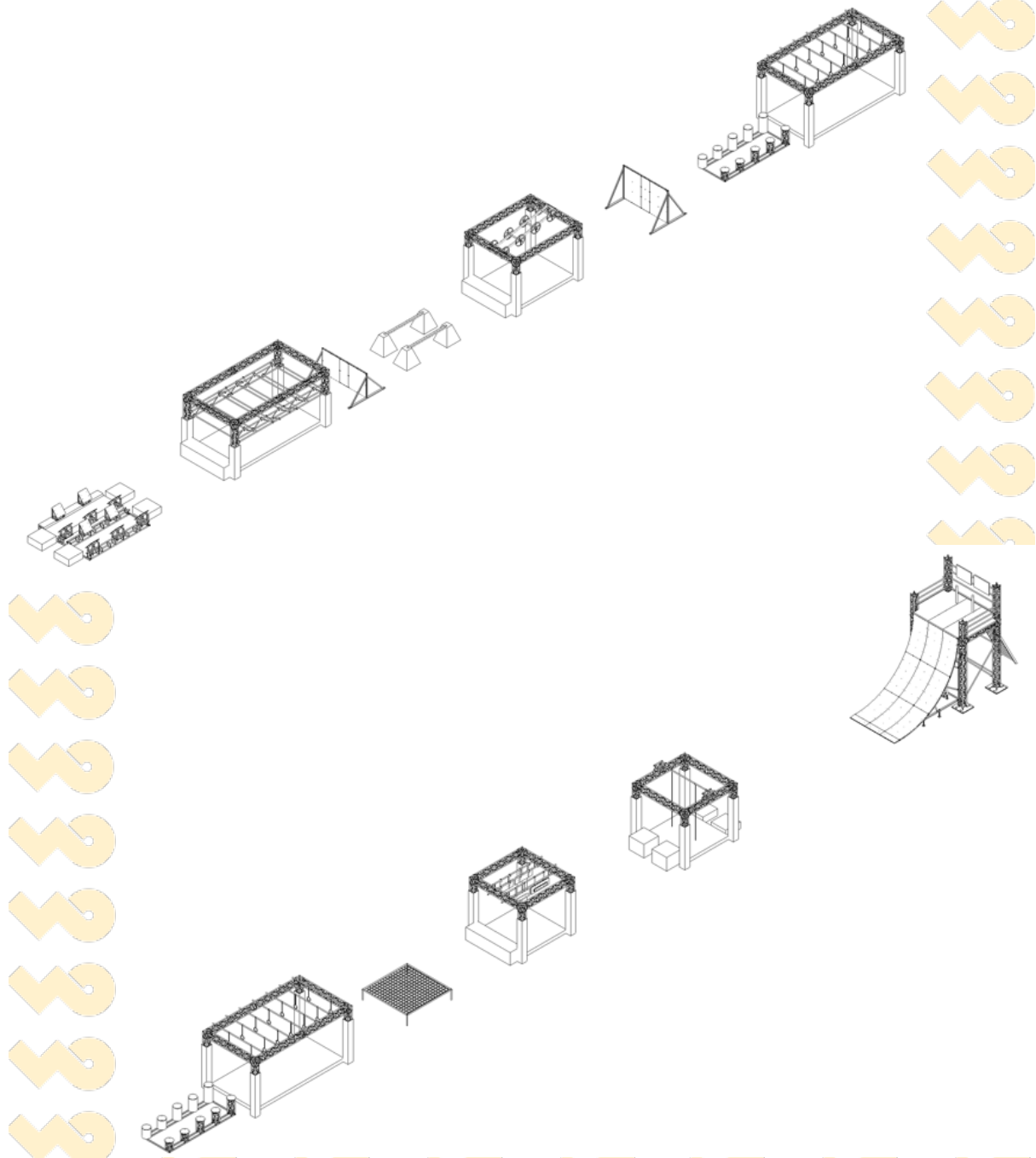

A general tolerance of 1% is allowable for all dimensions.

Bells for trussed obstacles (Monkey Bars, Rings, Wheels, Climbing Holds) shall be "cow bell" style, nominal dimensions 60 mm (2.5 inch) wide and 60 mm (2.5 inch) high but no more than 100 mm (4 inches) wide and 100 mm (4 inches) high. Bell tethers shall be semi flexible to prevent the tether wrapping over the support frame. PVC or hose pipe may be used over flexible tethers to prevent wrapping.

The 12 standard obstacles and structures are (in order):

- Starting platform
- (1) Offset Steps
- (2) Mini trampoline and Monkey Bars
- (3) 1.5 m Wall
- (4) Balance Beam
- (5) Wheels
- (6) 2.0 m Wall
- (7) Island Steps
- (8) Rings
- (9) Low Crawl
- (10) Climbing Holds
- (11) Tarzan Swing
- (12) Wave Wall and Finish platform

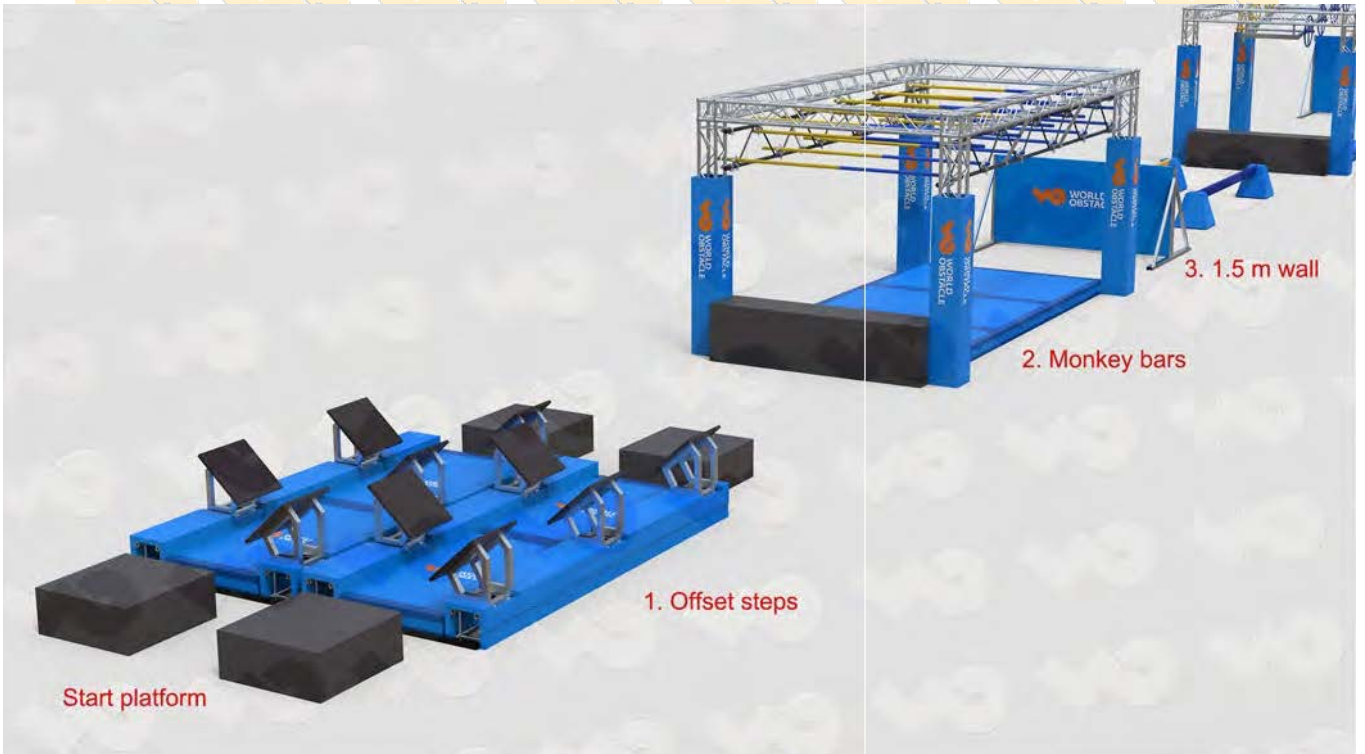

Obstacles 1 though 3

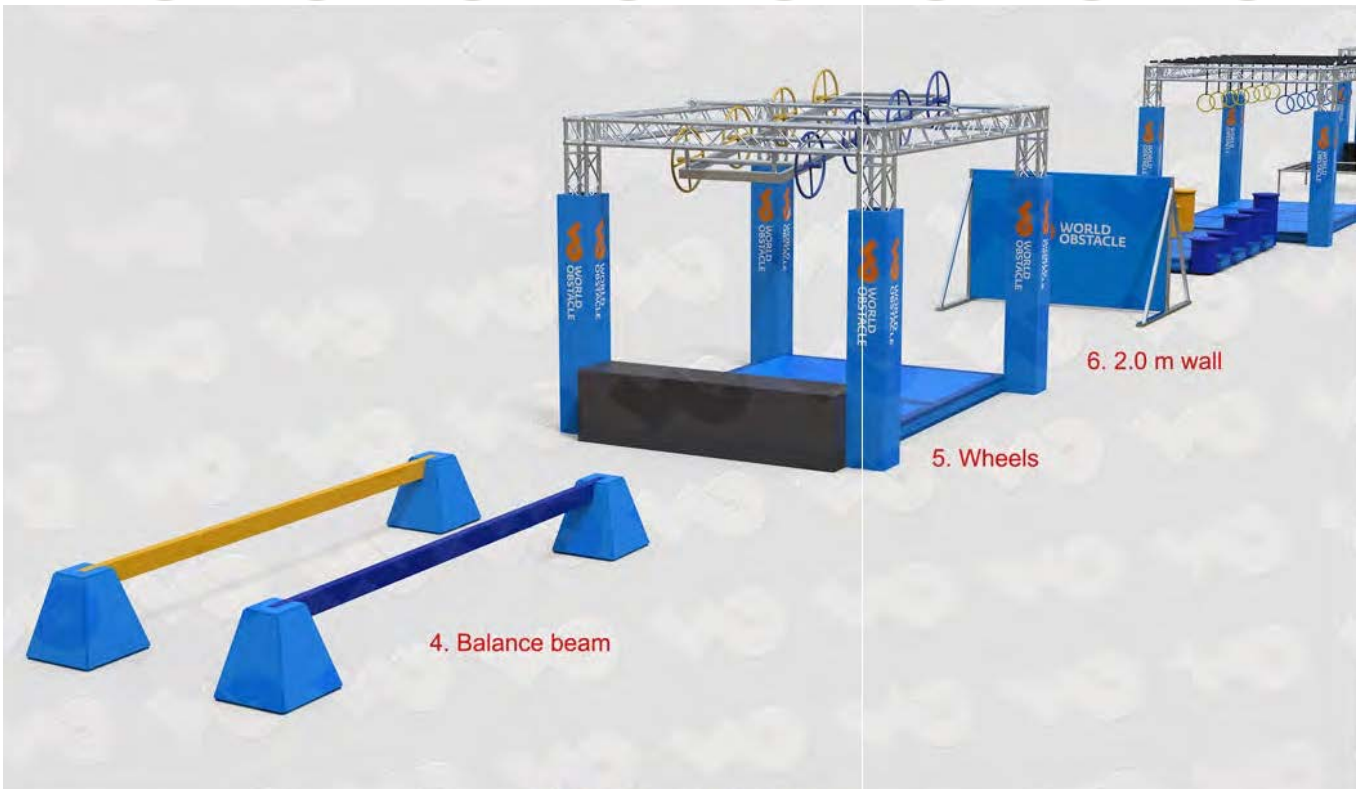

Obstacles 4 though 7

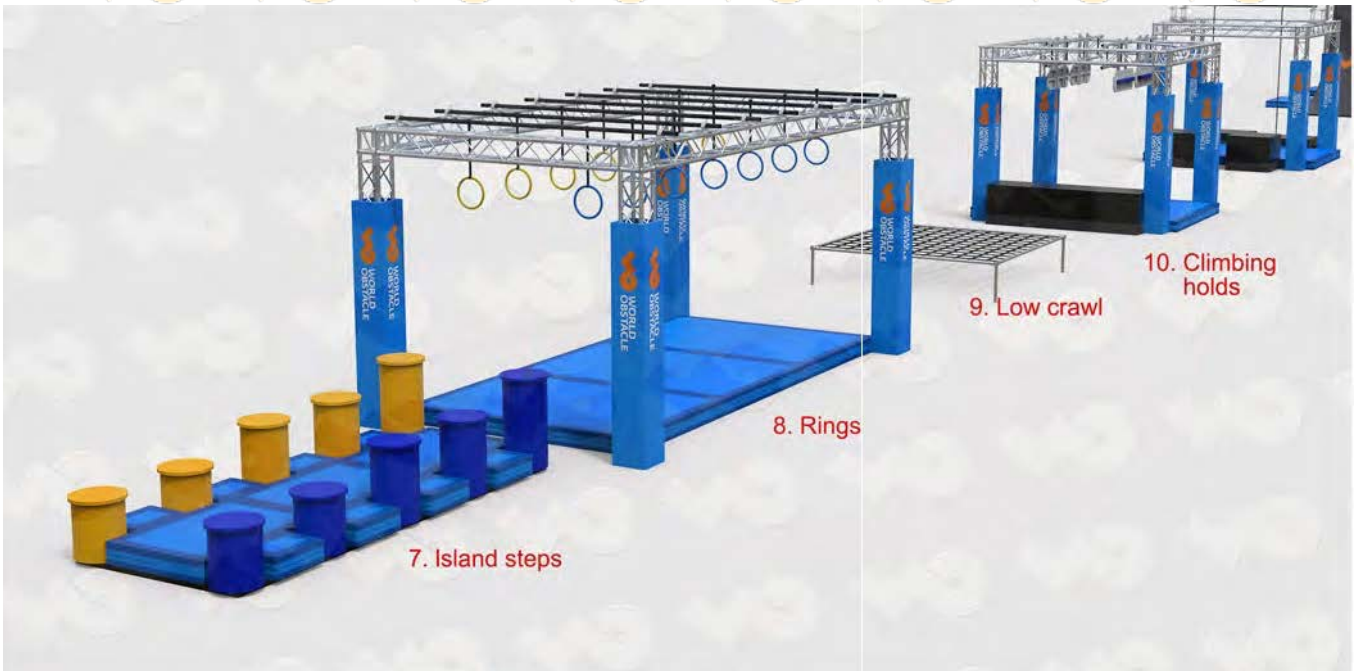

Obstacles 7 though 10



Obstacles 10 through 12

6. OBSTACLE DETAILS

Linear dimensions (including wave wall radius) shall be accurate to +/- 5 mm (3/16 inch) from reference datum. Radial dimensions (pipe diameters) and wall thicknesses shall be accurate to 5%.

A. Start Platform

The start platform is a level structure 400 mm high (including padding) and a minimum of 1,000 mm long and x 1,000 mm wide per lane. The platforms are placed no more than 400 mm from the first and last steps.

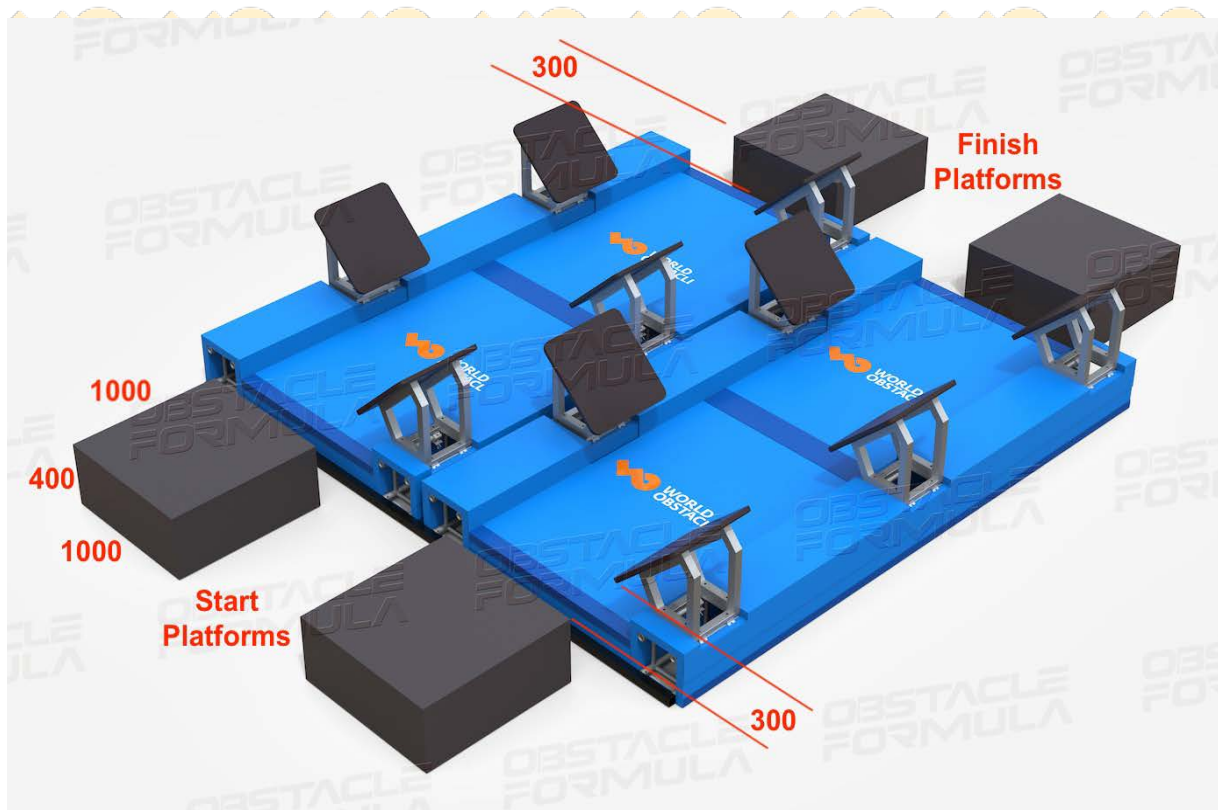

The start line is a vertical plane perpendicular to the course direction and 400 mm before the edge of the first step.

B. Obstacle 1 - Offset Steps

Offset steps include a finish platform 400 mm high, 1,000 mm long and x 1,000 mm wide. The bottom of each step is 400 mm from the ground.

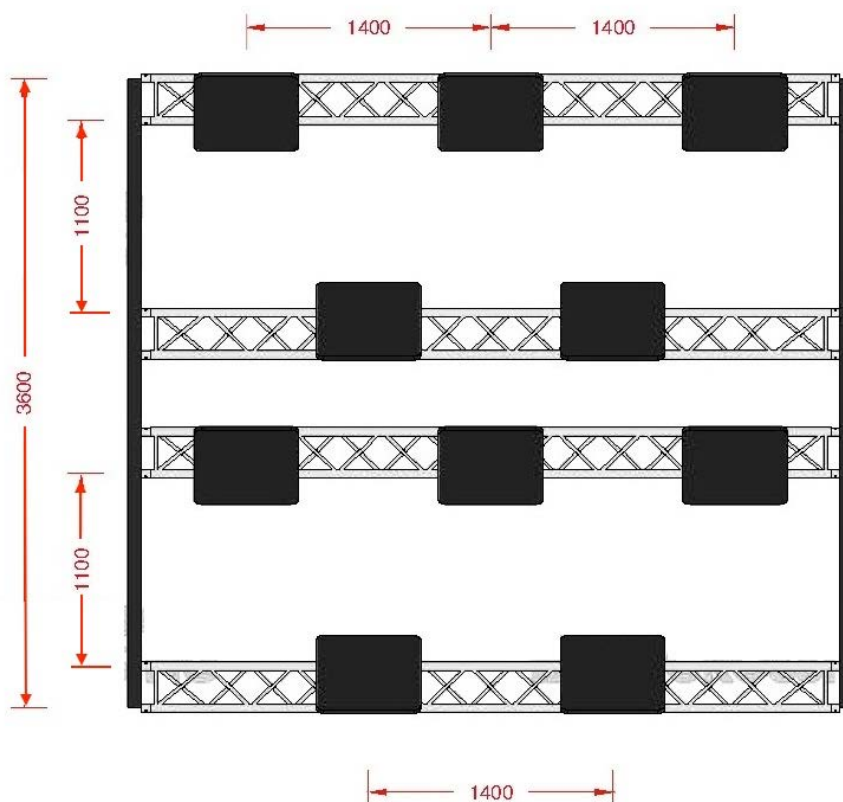
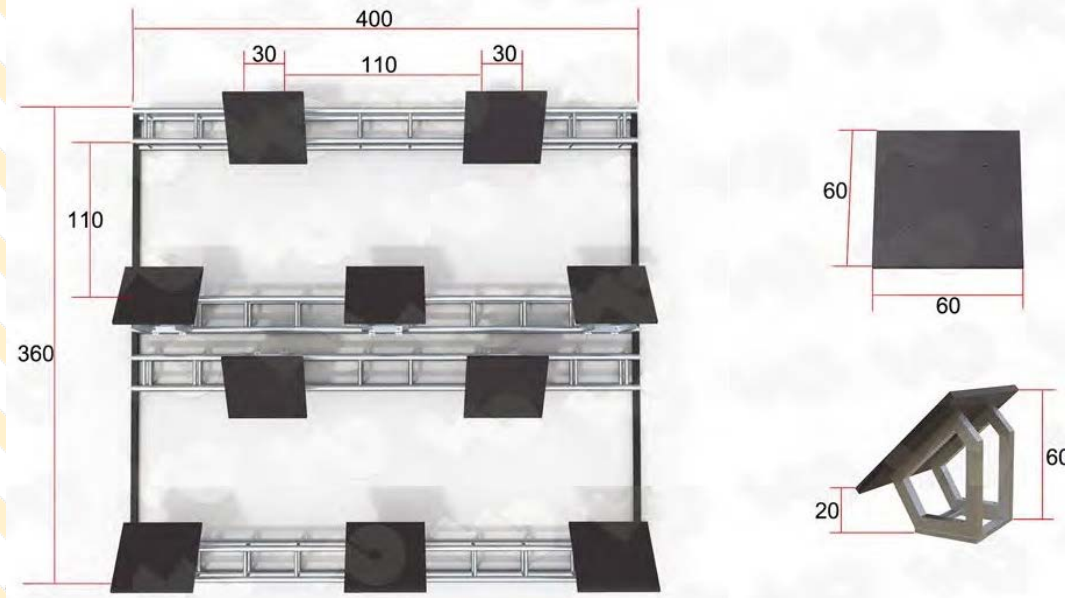

C. Obstacle 2 - Mini Trampoline and Monkey Bars

Mini tramp: 900 to 1,200 mm frame diameter, 200 to 300 mm height, 110+ kg load rating. Must be free of sharp or protruding edges.



Recommended inside frame width is 1,200 mm minimum per lane to provide clearance between the support frames and athletes.

All exposed edges should be smooth and free of protrusions. Support frames should be padded where (if) athletes can make contact.

Monkey bar outside diameter is 50 mm. Bars should be sufficiently ridged to minimize flex under load. Steel scaffold bars are recommended. Aluminium bars are acceptable, recommended minimum wall thickness 5 mm or with internal bracing.

There are 6 low bars and 5 high bars. Bars alternate from low (2400 from ground) to high (2700 mm to ground). The first and last bars are low.

The bell is 300 mm past the last bar (centre to centre). Bottom of the bell is 2300 mm above the ground (100 mm below the last bar).

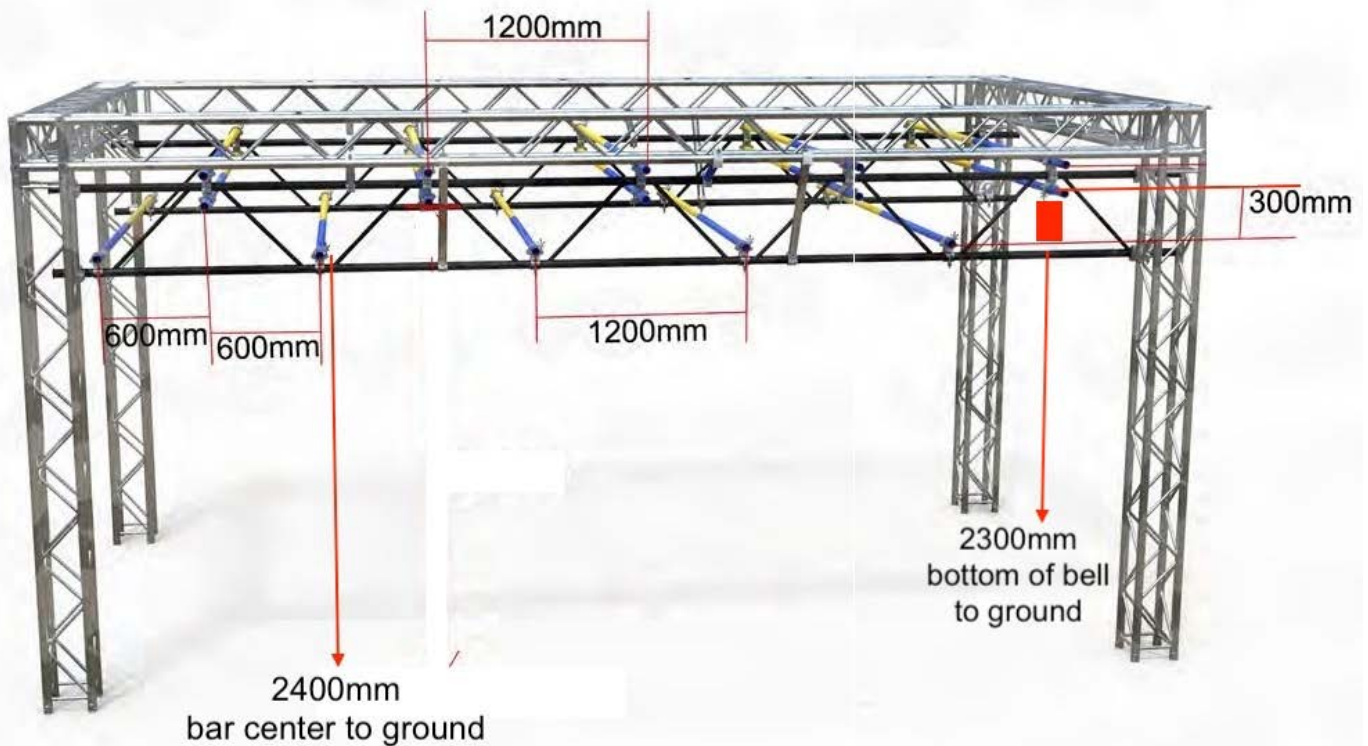

Notes on Truss (also known as stage or lighting truss)

Truss sizes vary but we strongly recommend using light-duty 12 x 12 inch truss (304.8 mm x 304.8 mm or equivalent.)

Plated truss allows 4-pattern bolted connections for horizontal members. A properly bolted horizontal 6,000 mm truss (two 3,000 mm sections) can support a static centre load of 482 kg, equivalent to 964 kg on an obstacle frame with two horizontal trusses.

Spigoted truss has a greater distance between the connections, which reduces the load on each connection. Properly connected spigots use double ended conical couplers with tapered shear pins and R-clips and are as strong, or stronger than plated truss.



Spigoted Truss

All truss connections must be carefully inspected and verified prior to use of an obstacle. Properly torqued electric drills should be used to assemble plated truss and 2 kg (3 lb) hammers are recommended for pinned spigot assembly. Pinned spigots must have ring locks in place.

Minimum wall thickness for light truss is 3 mm (1/8 inch) on the main tubes, which are 50 mm (2 inches) diameter. Diagonals are 25 mm (1 inch) diameter and 3 mm (1/8 inch) wall thickness.

D. Obstacle 3 - 1.5 m Wall

All exposed edges should be smooth and free of protrusions. Support frames shall not create a tripping hazard or interfere with athlete movement. Suggested width 1,500 per lane, minimum 1,200 mm.

Wall surfaces should be smooth (no texture) and capable of withstanding repeated impacts from athletes kicking the wall at full speed.

12 mm construction plywood, 5 mm Plexiglas (Perspex), 5 mm HDPE, 2 mm sheet metal or similar material is recommended.



E. Obstacle 4 - Balance Beam

All exposed edges should be smooth and free of protrusions.

Step surface (300 mm x 300 mm square start and finish steps) and beam should be non-slip.

Balance beams should be separated by 1,400 mm.

Beam width is 100 mm.

Padding on the beam top surfaces is recommended, minimum 10 mm thick closed cell foam or rubber recommended to reduce risk of injury in the event of a fall. Exposed corners must be padded.

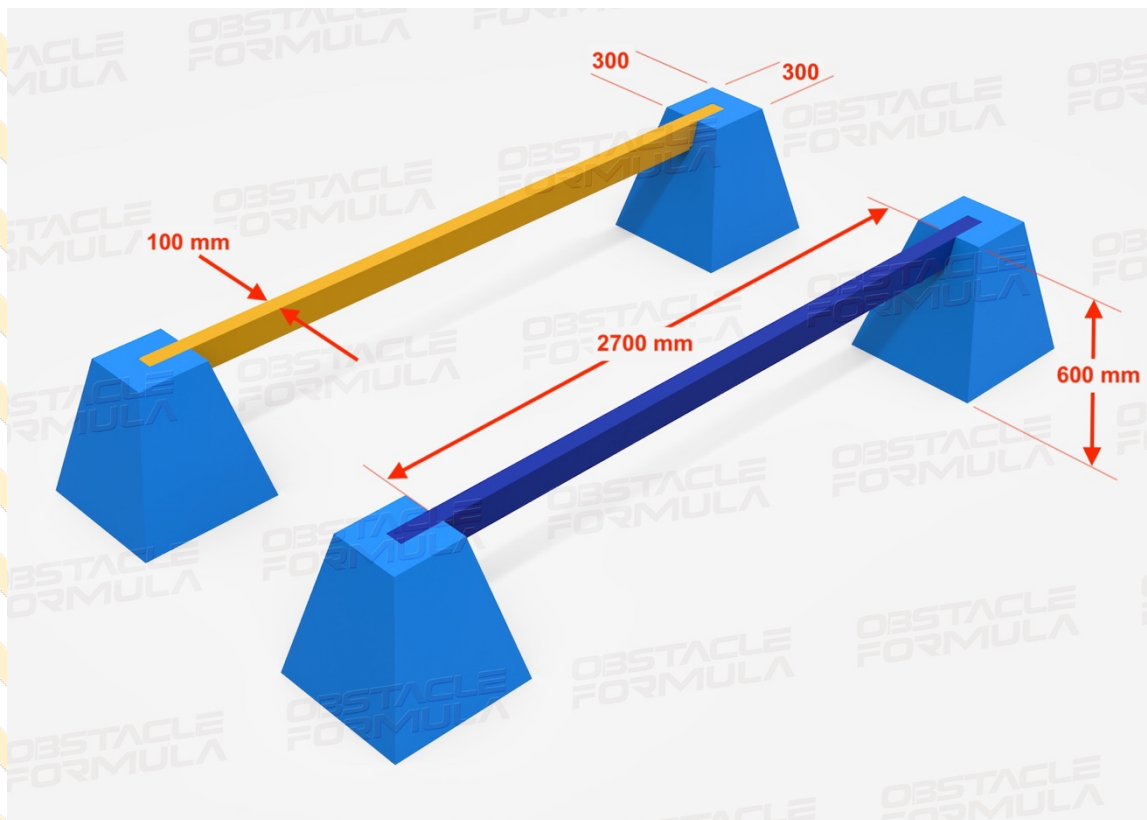

F. Obstacle 5 - Wheels

Inside frame width should be 1,200 mm minimum per lane (1,500 mm suggested) to provide clearance between the support frames and athletes.

All exposed edges should be smooth and free of protrusions. Step surface (600mm x 750 mm) should be non-slip. Support frames should be padded where (if) athletes can make contact.

First wheel starts in a vertical plane in-line with the end of the step surface. Wheels can be three or four spokes. Gradient of the wheels (slope) is 15% / 8.6 degrees.

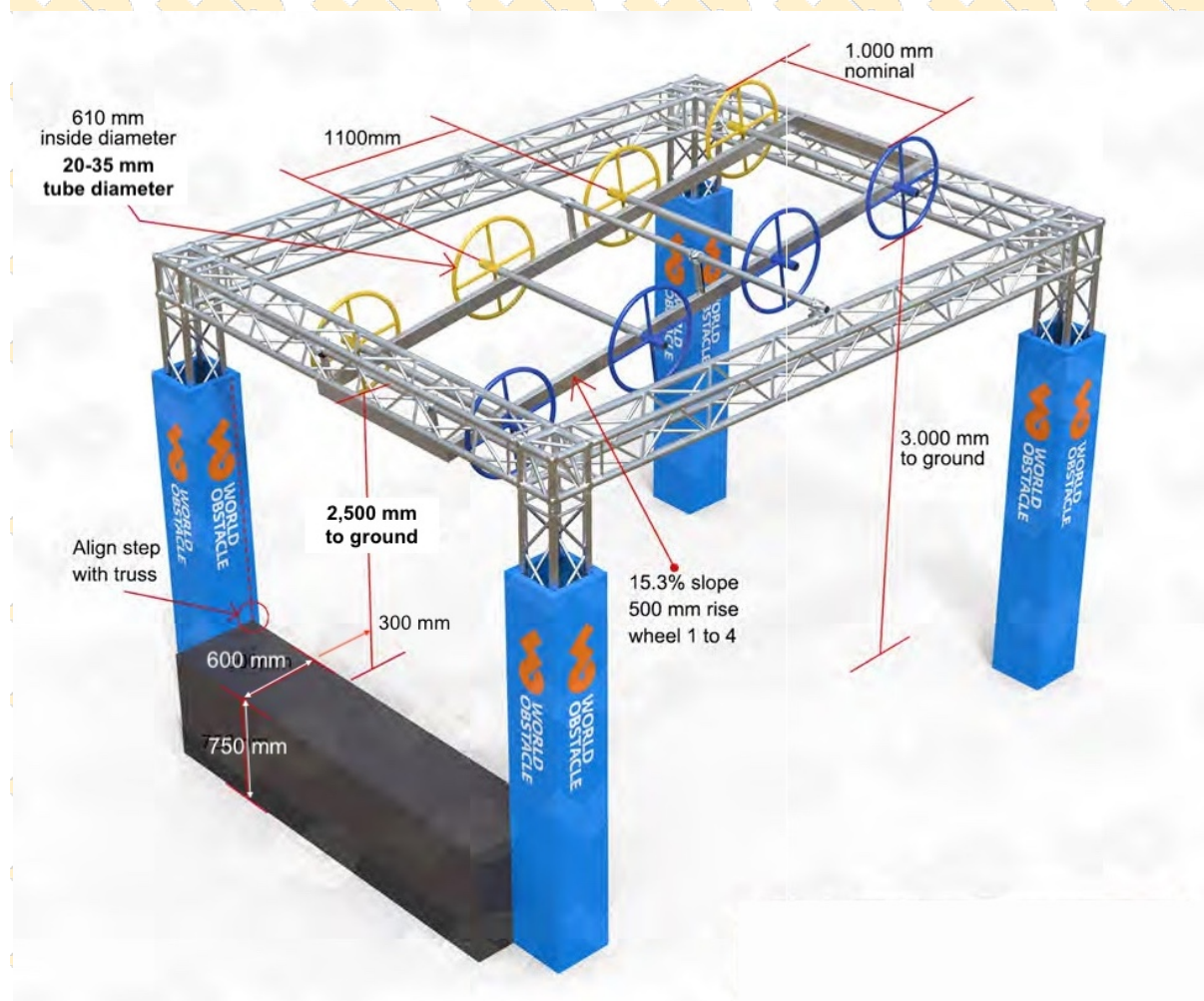

The bottom of the bell is the height of the bottom of the first wheels (2,500 mm to ground), 675 mm past the middle of the last wheel.

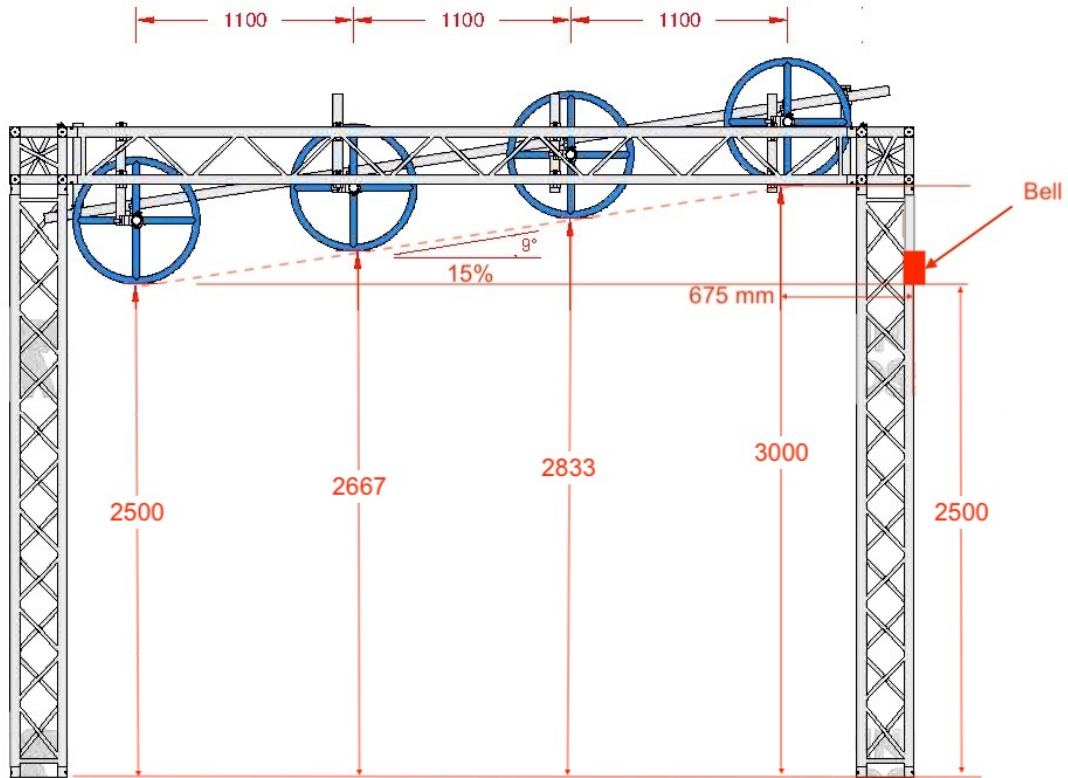

G. Obstacle 6 - 2.0 m Wall

All exposed edges should be smooth and free of protrusions. Support frames shall not create a tripping hazard or interfere with athlete movement. Suggested width 1,500 per lane, minimum 1,200 mm (two acceptable configurations below)

Wall surfaces should be smooth (no texture but not slippery) and capable of withstanding repeated impacts from athletes kicking the wall at full speed.

12 mm construction plywood, 5 mm Plexiglas (Perspex), 5 mm HDPE, 2 mm sheet metal or similar material is recommended.



H. Obstacle 7 - Island Steps

All exposed edges should be smooth and free of protrusions. Step surface should be non-slip. Nominal spacing 1,500 mm.

Support frames shall not create a tripping hazard or interfere with athlete movement. Support frames should be padded where (if) athletes can make contact.

Steps shall be stable in all directions under loads created by athletes running at full speed.



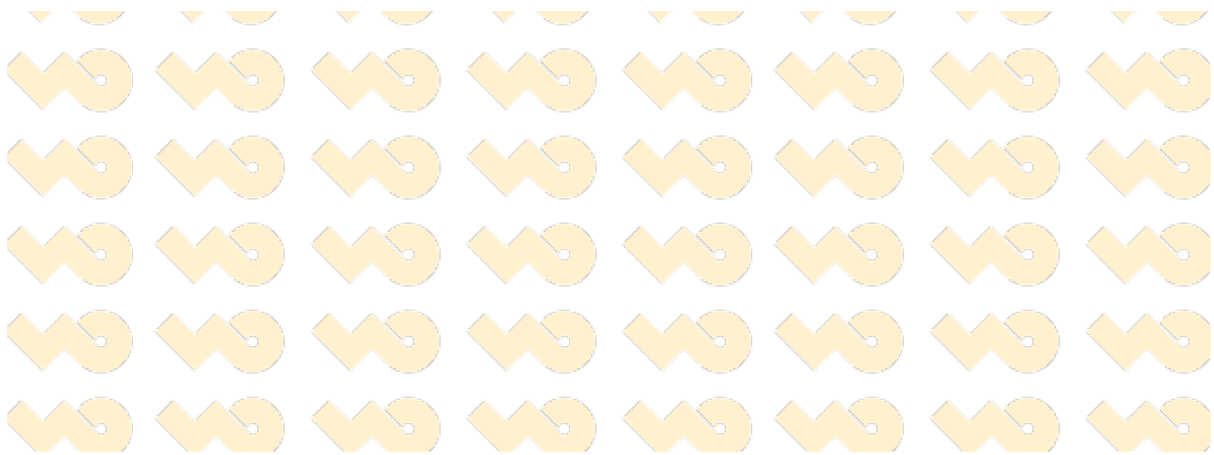
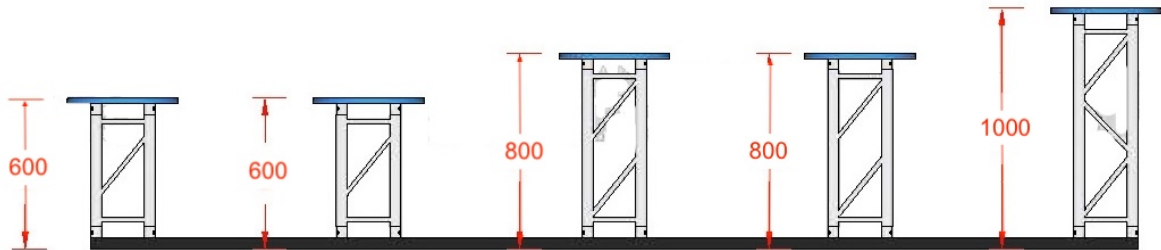
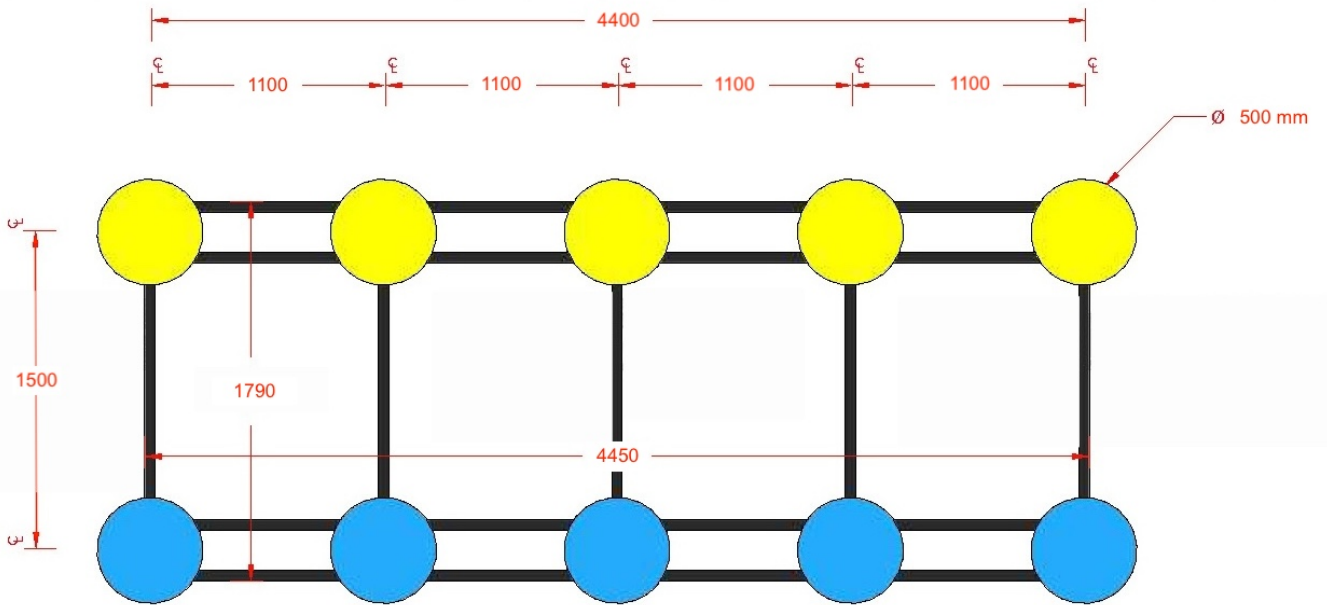

I. Obstacle 8 - Rings

Inside frame width should be 1,200 mm minimum per lane (1,500 mm suggested) to provide clearance between the support frames and athletes.

All exposed edges should be smooth and free of protrusions. Step surface (600mm x 750 mm) should be non-slip. Step 750 mm high x minimum 600 mm deep. Support frames should be padded where (if) athletes can make contact.

Ring tube diameter 20-35 mm. Swing length (top attachment pivot point to ring bottom) 940 mm.

The bottom of the bell is 100 mm below the bottom of the rings (2300 mm to ground).

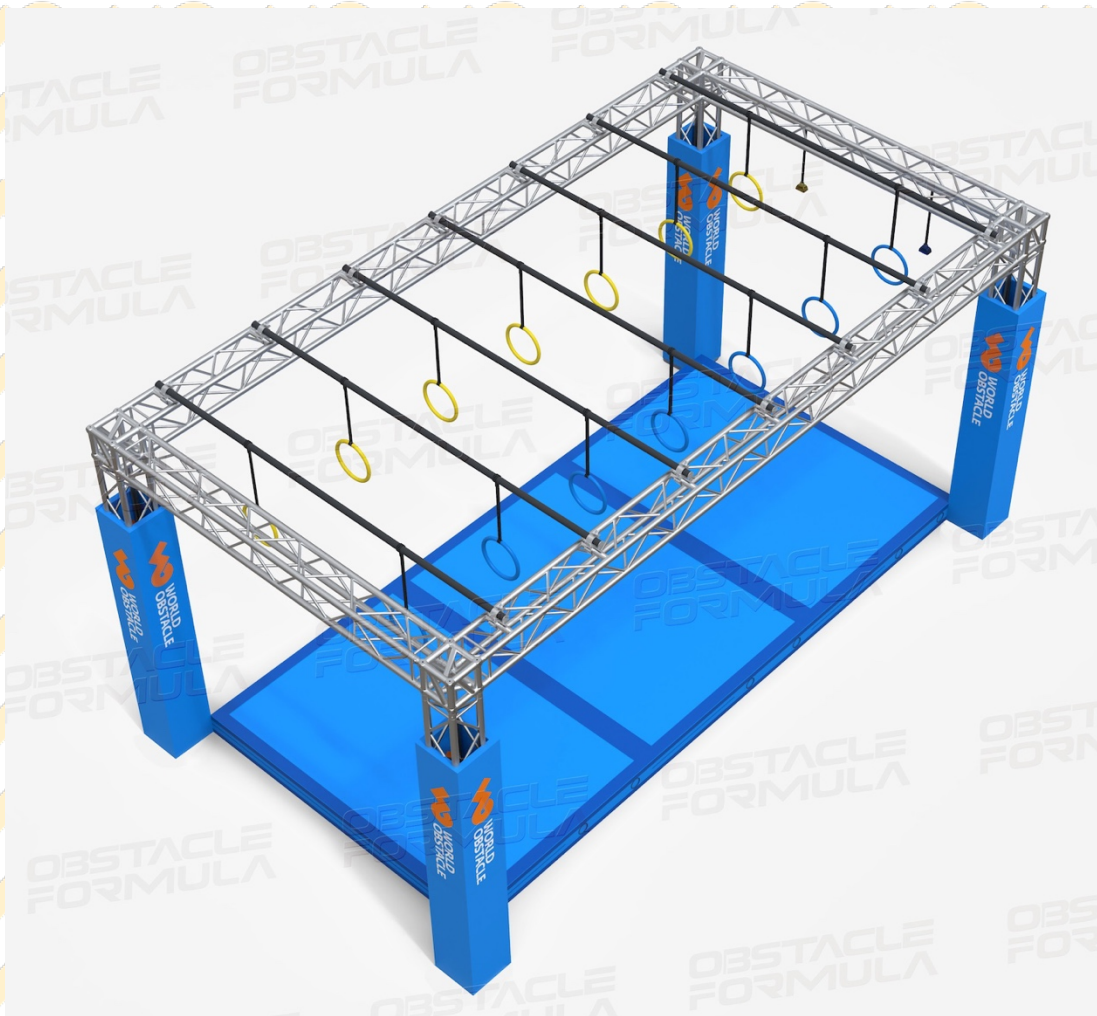

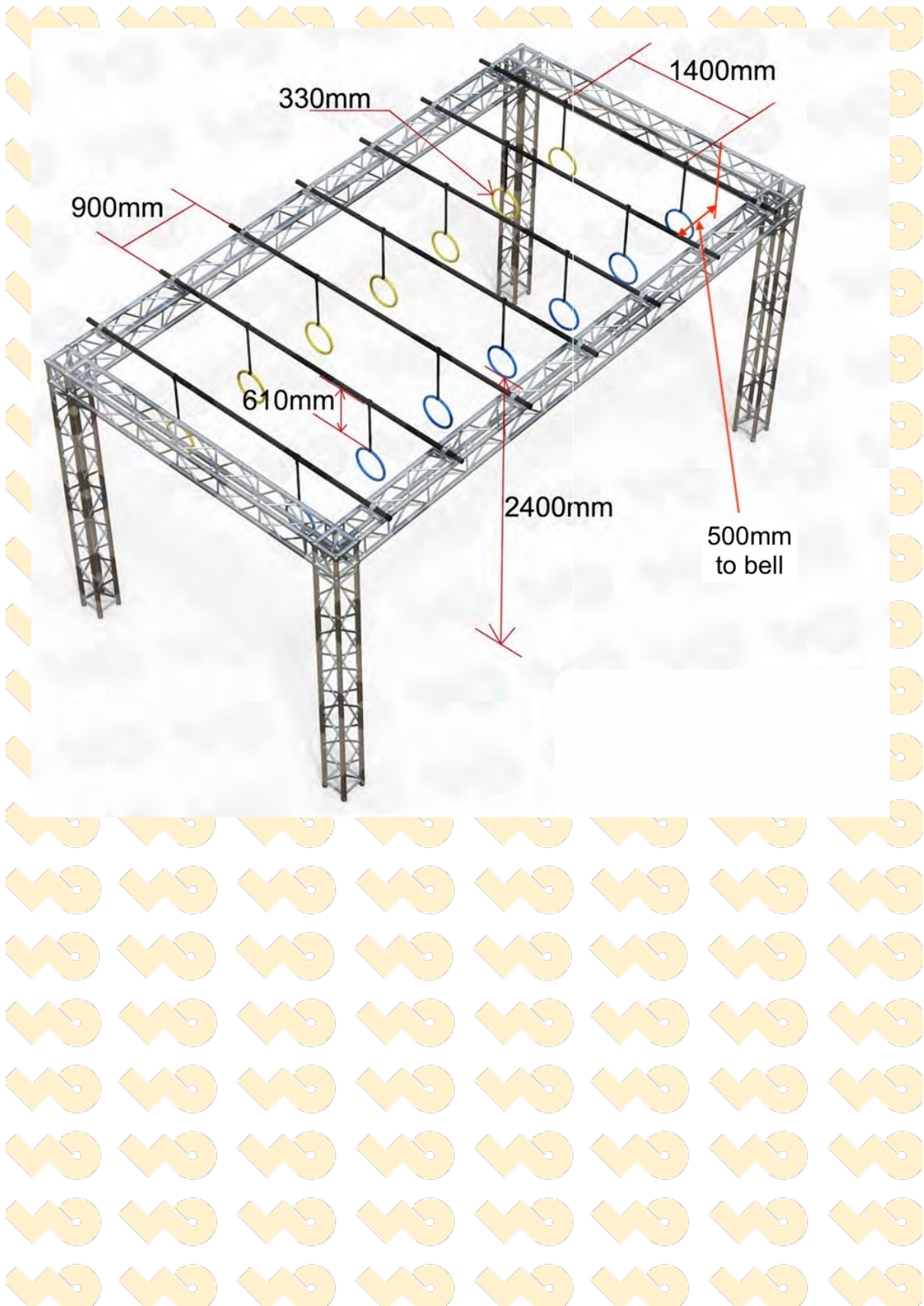

J. Obstacle 9 - Low Crawl

Net tight and must be suspended in a manner that prevents athletes lifting it.

Framing shall be rigid and fixed to prevent movement. Frame width 1,200 m per lane minimum, 1,500 mm recommended.

The ground surface under the padding (20 mm thick and 80 kg/m³ martial arts mats or equivalent) shall be flat, level, and free from rocks, gravel or any item that could cause injury.

Padding shall be smooth to allow sliding and secured to the ground to prevent movement and separation of individual pads.

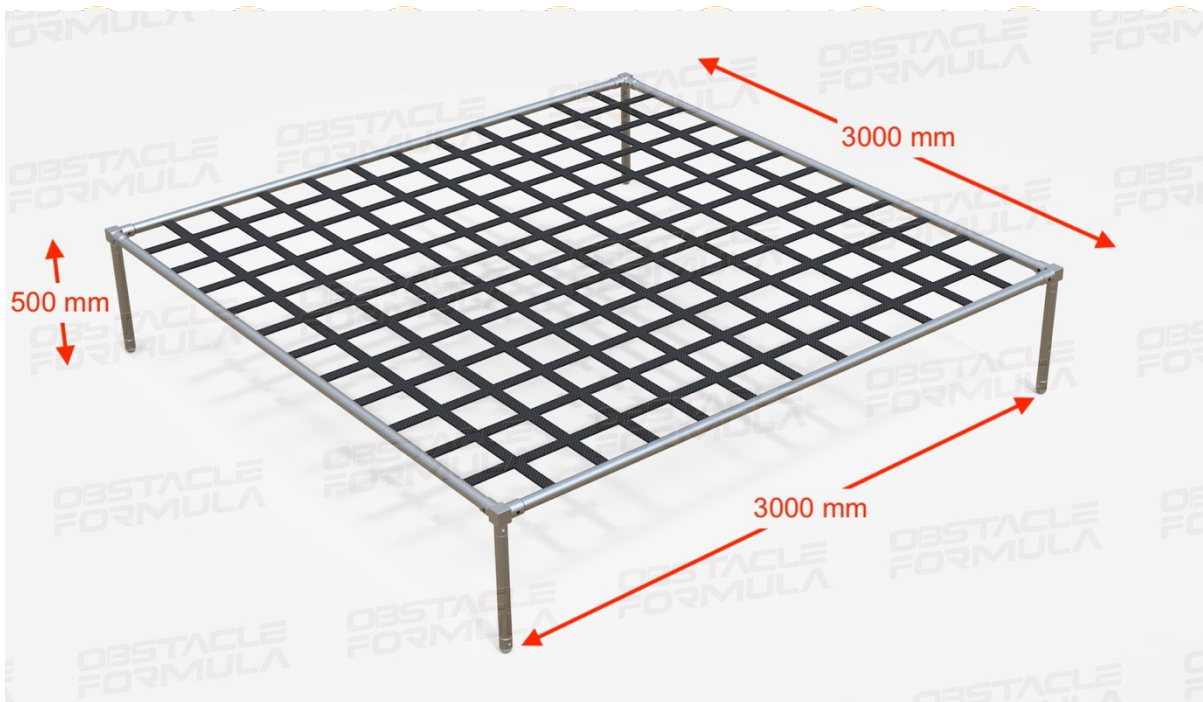

K. Obstacle 10 - Climbing Holds

Inside frame width should be 1,200 mm minimum per lane (1,500 mm suggested) to provide clearance between the support frames and athletes.

All exposed edges should be smooth and free of protrusions. Step surface (600mm x 750 mm) should be non-slip. Step 750 mm high x minimum 600 mm deep. Support frames should be padded where (if) athletes can make contact.

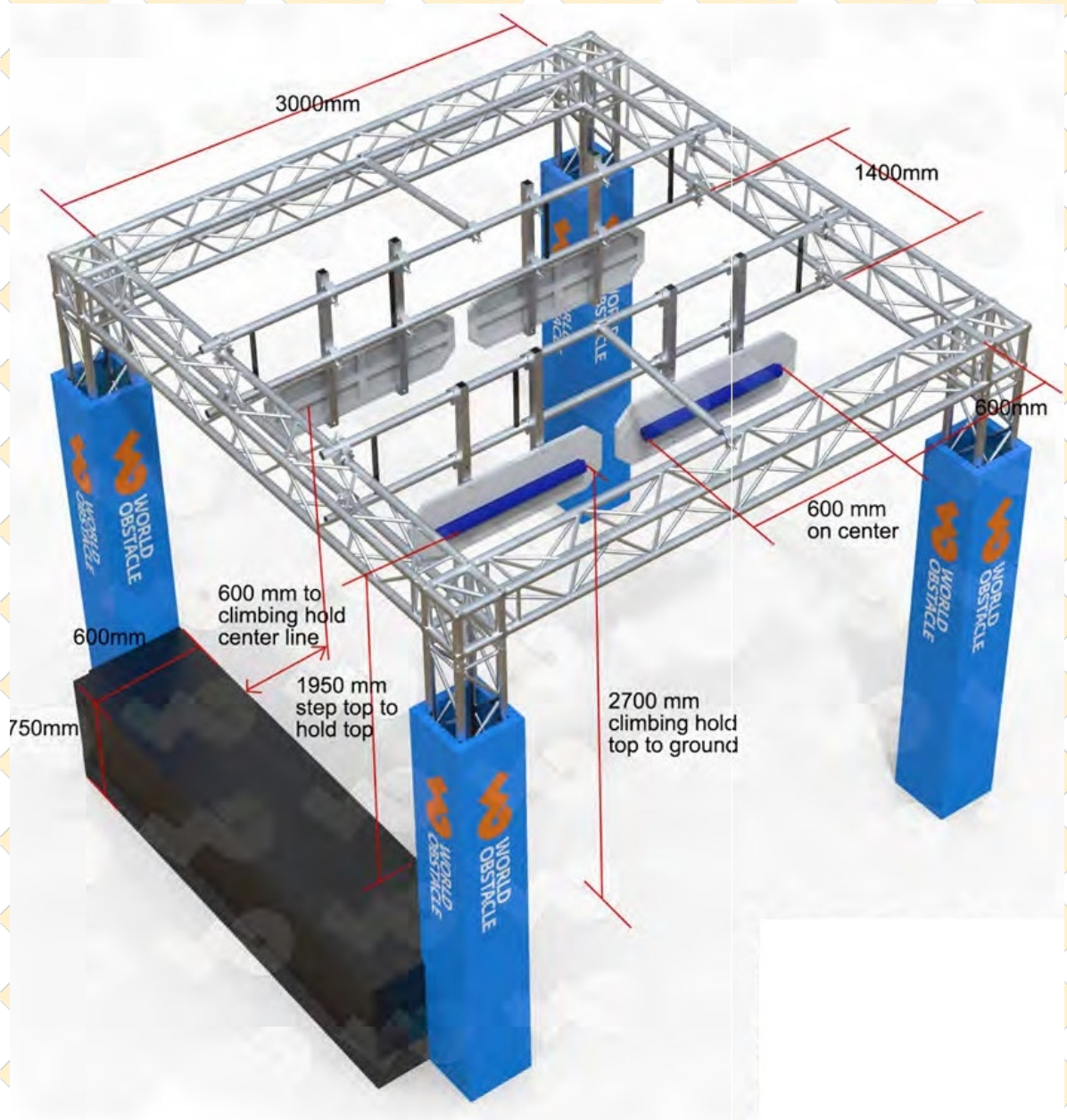

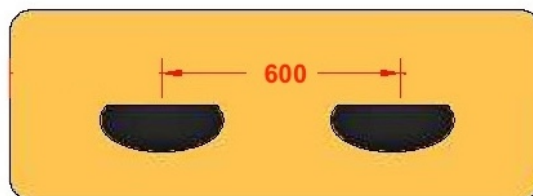
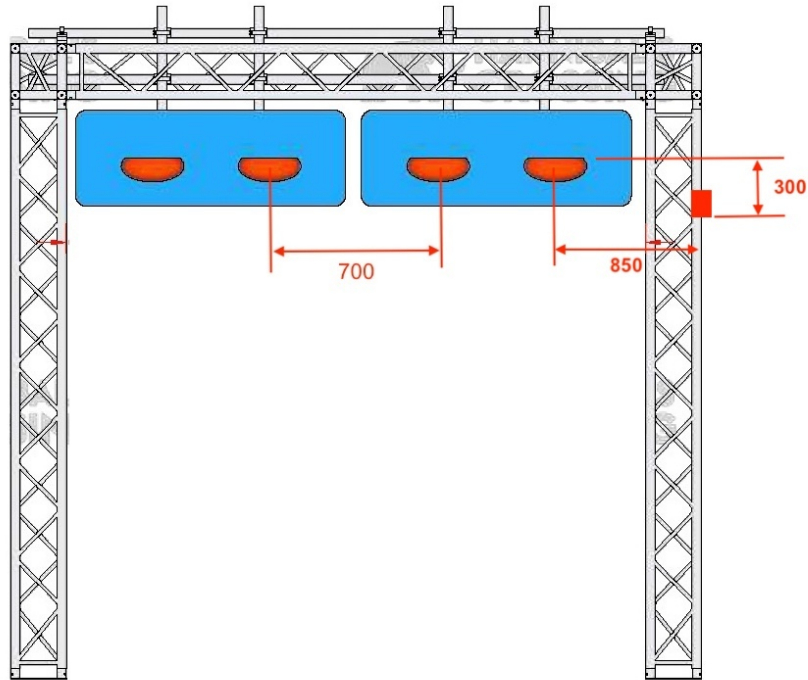

Four (4) climbing holds shall be spaced at 600 mm (centre to centre), starting 600 mm from the end of the step. Right lane holds shall face right, left lane holds shall face left.

Bells are located 850 mm past the centre of the last holds and the bottom of the bells are 300 mm below the top of the holds (2400 mm to ground).

Climbing holds are 2-hand juggy hold like the Atomik XXXL Ledge #1, image below (orange):



Holds must have a “climbing hold” texture and be free of finger traps, sharp edges, rough spots, and any feature that could cause injury. Ledges shall have a radius that can be easily gripped by small and large hands (30 mm to 50 mm radius). Ledge length shall accommodate two large hands for matching grip, 250 to 350 mm. Ledge depth shall be sufficient to accommodate large hands, 100 mm nominal.

Two set of four holds may be provided for each lane, a right-hand set and a left-hand set. Side to side (lateral) clearance between holds shall allow athletes using both inside lanes sufficient room to pass.

Lateral clearance to vertical supports shall allow athletes to pass and minimize the risk of hitting the supports (example of clearances for a 3000mm wide truss frame below.) Padding on verticals is recommended.

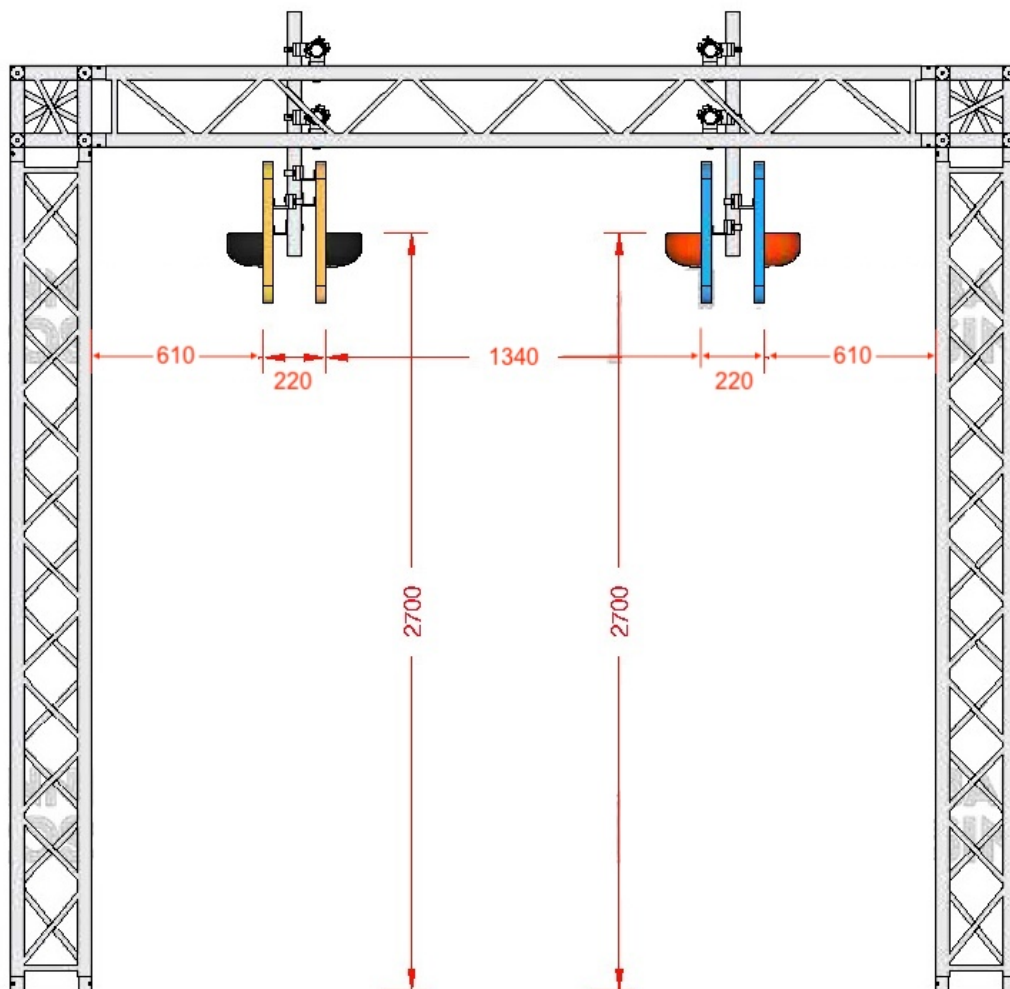

Minimum recommended horizontal spacing between vertical supports is 3000 mm.

Obstacle 11 - Tarzan Swing

Inside frame width should be 1,200 mm minimum per lane (1,500 mm suggested) to provide clearance between the support frames and athletes.

All exposed edges should be smooth and free of protrusions. Step surface (600mm x 750 mm) should be non-slip. Support frames should be padded where (if) athletes can make contact. There are no bells on the Tarzan Swing.

Rope diameter 38 mm nominal, 5000 mm long minimum. Rope material should be selected for strength, grip when wet, flexibility, and weather resistance, e.g. Manila fibre, Polydac (polypropylene – Dacron), etc. Smooth synthetic fibres that are slippery may be difficult to hold and can cause rope burns.

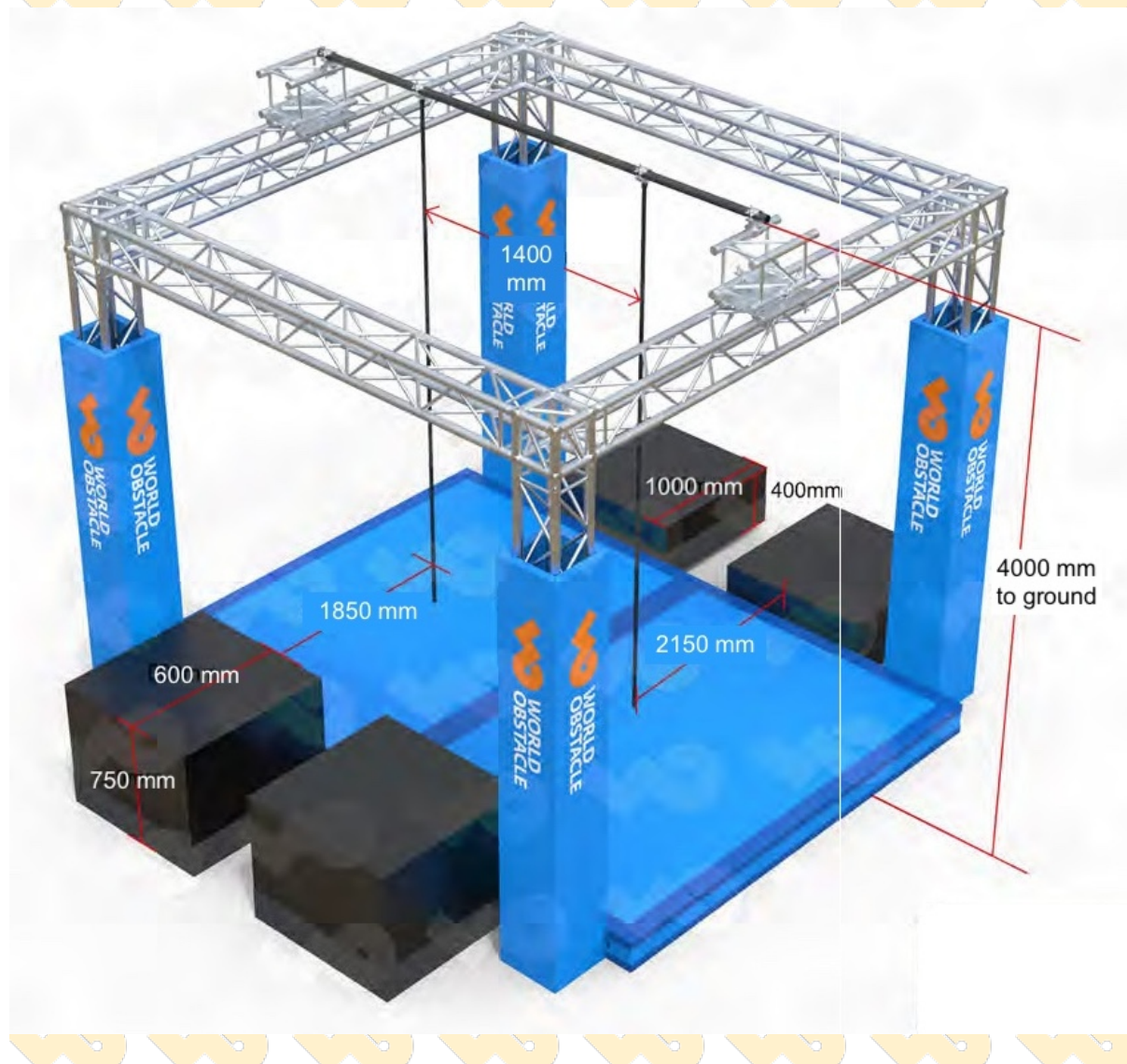

L. Obstacle 12 - Wave Wall

All exposed edges should be smooth and free of protrusions. Wave wall curved surface shall be smooth but not slippery, e.g. Skatelight, wood painted with exterior matt paint, epoxy, or polyurethane. 1,200 mm lane width minimum.

Grip textures such as sand or pool decking is prohibited.

Railing height shall be 864 mm to 965 mm per the International Building Code (IBC).



M. Finish Platform

The finish platform shall be constructed to support 480 kg (six people) evenly distributed on the deck: two athletes, two judges and two camera operators.

Railings shall have a continuous horizontal top bar at IBC height on both sides and the back. At least one additional horizontal railing shall be included (two recommended), evenly spaced between the deck and top bar.

N. Finish Line

The finish line is a vertical plane through the finish buttons, perpendicular to the direction of the course. The finish button shall be supported on a vertical post capable of withstanding an 80 kg force at the top of the post in any direction. If laser timing is used, the finish laser shall be across the top of the buttons, 5000 mm above ground.

Each finish button shall be connected to the timing system to stop the time and the clock for the athlete. Timing clocks for each lane should be placed above and behind the finish buttons, visible to spectators. Suggested height 2000 to 2500 mm above the platform.

Finish mechanisms such as smoke, fireworks, steam, lights may be activated by the finish button.



7. COURSE CHECKLIST

Enter measurements below.

Course length:

Maximum slope: longitudinal (lengthwise):

Maximum slope: lateral (side to side):

Lane width:

Start platform:

Offset steps:

Mini trampoline:

Monkey bars:

1.5 m wall:

Balance beam:

Wheels:

2.0 m wall:

Island steps:

Rings:

Low crawl:

Climbing holds:

Tarzan swing:

Wave wall:

Finish platform:

Finish button:

APPENDIX A – Scaffold Frames

Ring lock scaffold example. *Images courtesy of OCR Russia*

